

## EMC TEST REPORT

<b>Report Reference No</b> .....	ZKT-2019073339E
Date of issue.....	Aug. 02, 2019
Total number of pages.....	41
<b>Testing Laboratory</b> .....	<b>Shenzhen ZKT Technology Co., Ltd.</b>
Address.....	2F, Building 1, Maozhoushan Industrial Park, Houting Community, Shajing Street, Bao'an District, Shenzhen, China
<b>Applicant's name</b> .....	<b>ZHEJIANG JURRY ELECTRONICS Co., Ltd.</b>
Address.....	No. 3 nanyang 2nd Road, duqiao south industrial development zone, linhai city, zhejiang province
<b>Test specification:</b>	
Standards.....	EN 55014-1:2017 EN 61000-3-2:2014, EN 61000-3-3:2013 EN 55014-2:2015 EN 61000-4-2:2009, EN 61000-4-3:2006+A1:2008+A2:2010, EN 61000-4-4:2012, EN 61000-4-5:2014, EN 61000-4-6:2014, EN 61000-4-11:2004
Non-standard test method.....	N/A
<b>Test Report Form No</b> .....	--
Test Report Form(s) Originator.....	ZKT Testing
Master TRF.....	Dated: 2017-06
<b>This test report is specially limited to the above client company and product model only. It may not be duplicated without prior written consent of ZKT Test.</b>	
<b>Test item description</b> .....	charger
Trade Mark.....	
Manufacturer.....	ZHEJIANG JURRY ELECTRONICS Co., Ltd. No. 3 nanyang 2nd Road, duqiao south industrial development zone, linhai city, zhejiang province
Model/Type reference.....	JC1K2-72 JC1K2-12, JC1K2-24, JC1KC-36, JC1K2-48, JC1K2-60, JC1KC-84, JC1K2-96, JC1K2-108, JC1K2-144
Ratings.....	Input: AC230V, 50Hz, 6A Output: DC72V, 10A

**Testing procedure and testing location:**

**Testing Laboratory**.....: **Shenzhen ZKT Technology Co., Ltd.**

**Address**.....: 2F, Building 1, Maozhoushan Industrial Park, Houting Community, Shajing Street, Bao'an District, Shenzhen, China

**Date of Test**.....: Jul. 26, 2019 to Aug. 02, 2019

**Tested by (name + signature)**.....: Peter Huang



**Reviewer (name + signature)**.....: Simon Gong



**Approved (name + signature)**.....: Awen He



## TABLE OF CONTENT

Test Report Declaration	Page
<b>1. GENERAL INFORMATION.....</b>	<b>5</b>
1.1. Description of Device (EUT).....	5
1.2. Tested System Details.....	5
1.3. Test Uncertainty.....	5
<b>2. TEST INSTRUMENT USED.....</b>	<b>6</b>
<b>3. CONDUCTED EMISSION AT THE MAINS TERMINALS TEST.....</b>	<b>9</b>
3.1. Block Diagram Of Test Setup.....	9
3.2. Test Standard.....	9
3.3. Power Line Conducted Emission Limit.....	9
3.4. EUT Configuration on Test.....	9
3.5. Operating Condition of EUT.....	9
3.6. Test Procedure.....	10
3.7. Test Result.....	10
<b>4. RADIATION EMISSION TEST.....</b>	<b>13</b>
4.1. Block Diagram of Test Setup.....	13
4.2. Test Standard.....	13
4.3. Radiation Limit.....	13
4.4. EUT Configuration on Test.....	14
4.5. Operating Condition of EUT.....	14
4.6. Test Procedure.....	14
4.7. Test Result.....	14
<b>5. HARMONIC CURRENT EMISSION TEST.....</b>	<b>17</b>
5.1. Block Diagram of Test Setup.....	17
5.2. Test Standard.....	17
5.3. Operating Condition of EUT.....	17
5.4. Test Procedure.....	17
5.5. Test Results.....	17
<b>6. VOLTAGE FLUCTUATIONS &amp; FLICKER TEST.....</b>	<b>20</b>
6.1. Block Diagram of Test Setup.....	20
6.2. Test Standard.....	20
6.3. Operating Condition of EUT.....	20
6.4. Test Procedure.....	20
6.5. Test Results.....	20
<b>7. ELECTROSTATIC DISCHARGE IMMUNITY TEST.....</b>	<b>22</b>
7.1. Block Diagram of Test Setup.....	22
7.2. Test Standard.....	22
7.3. Severity Levels and Performance Criterion.....	22
7.4. EUT Configuration.....	23
7.5. Operating Condition of EUT.....	23
7.6. Test Procedure.....	23
7.7. Test Results.....	24
<b>8. RF FIELD STRENGTH SUSCEPTIBILITY TEST.....</b>	<b>25</b>
8.1. Block Diagram of Test Setup.....	25
8.2. Test Standard.....	25
8.3. Severity Levels and Performance Criterion.....	25
8.4. EUT Configuration on Test.....	26
8.5. Operating Condition of EUT.....	26
8.6. Test Procedure.....	27
8.7. Test Results.....	27

<b>9. ELECTRICAL FAST TRANSIENT/BURST IMMUNITY TEST.....</b>	<b>28</b>
9.1. Block Diagram of EUT Test Setup.....	28
9.2. Test Standard.....	28
9.3. Severity Levels and Performance Criterion.....	28
9.4. EUT Configuration on Test.....	29
9.5. Operating Condition of EUT.....	29
9.6. Test Procedure.....	29
9.7. Test Results.....	30
<b>10. SURGE TEST.....</b>	<b>31</b>
10.1. Block Diagram of EUT Test Setup.....	31
10.2. Test Standard.....	31
10.3. Severity Levels and Performance Criterion.....	31
10.4. EUT Configuration on Test.....	32
10.5. Operating Condition of EUT.....	32
10.6. Test Procedure.....	32
10.7. Test Result.....	33
<b>11. INJECTED CURRENTS SUSCEPTIBILITY TEST.....</b>	<b>34</b>
11.1. Block Diagram of EUT Test Setup.....	34
11.2. Test Standard.....	34
11.3. Severity Levels and Performance Criterion.....	34
11.4. EUT Configuration on Test.....	35
11.5. Operating Condition of EUT.....	35
11.6. Test Procedure.....	35
11.7. Test Result.....	36
<b>12. VOLTAGE DIPS AND INTERRUPTIONS TEST.....</b>	<b>37</b>
12.1. Block Diagram of EUT Test Setup.....	37
12.2. Test Standard.....	37
12.3. Severity Levels and Performance Criterion.....	37
12.4. EUT Configuration on Test.....	38
12.5. Operating Condition of EUT.....	38
12.6. Test Procedure.....	38
12.7. Test Result.....	38
<b>13. EUT PHOTOGRAPHS.....</b>	<b>39</b>
<b>14. EUT TEST PHOTOGRAPHS.....</b>	<b>41</b>

## 1. GENERAL INFORMATION

### 1.1. Description of Device (EUT)

EUT : charger  
JC1K2-72  
Model Number : JC1K2-12, JC1K2-24, JC1KC-36, JC1K2-48, JC1K2-60,  
JC1KC-84, JC1K2-96, JC1K2-108, JC1K2-144  
Trademark : jury  
Model Difference : N/A  
Power Supply : Input: AC230V, 50Hz, 6A  
Output: DC72V, 10A

Note:

### 1.2. Tested System Details

None.

### 1.3. Test Uncertainty

Conducted Emission  
Uncertainty :  $\pm 2.66\text{dB}$

Radiated Emission Uncertainty :  $\pm 4.26\text{dB}$

## 2. TEST INSTRUMENT USED

### For Conducted Emission at the mains terminals Test

Conducted Emission Test ( A --- site )					
Equipment	Manufacturer	Model#	Serial#	Last Cal.	Next Cal.
843 Shielded Room	ChengYu	843 Room	843	Aug. 25, 2018	Aug. 26, 2019
EMI Receiver	R&S	ESCI	101421	Aug. 25, 2018	Aug. 26, 2019
LISN	SCHWARZBECK	NSLK8127	812779	Aug. 25, 2018	Aug. 26, 2019
Pulse Limiter	R&S	ESH3-Z2	100681	Aug. 25, 2018	Aug. 26, 2019
843 Cable 1#	FUJIKURA	843C1#	001	Aug. 25, 2018	Aug. 26, 2019

### For Radiated Emission Test

Radiation Emission Test (966 chamber)					
Equipment	Manufacturer	Model#	Serial#	Last Cal.	Next Cal.
966 chamber	ChengYu	966 Room	966	Aug. 25, 2018	Aug. 26, 2019
Spectrum Analyzer	Agilent	E4407B	MY45109572	Aug. 25, 2018	Aug. 26, 2019
Amplifier	Schwarzbeck	BBV9743	9743-119	Aug. 25, 2018	Aug. 26, 2019
Amplifier	Schwarzbeck	BBV9718	9718-270	Aug. 25, 2018	Aug. 26, 2019
Log-periodic Antenna	Schwarzbeck	VULB9160	VULB9160-3369	Aug. 25, 2018	Aug. 26, 2019
EMI Receiver	R&S	ESCI	101421	Aug. 25, 2018	Aug. 26, 2019
Horn Antenna	Schwarzbeck	BBHA9120D	9120D-1275	Aug. 25, 2018	Aug. 26, 2019
966 Cable 1#	CHENGYU	966	004	Aug. 25, 2018	Aug. 26, 2019
966 Cable 2#	CHENGYU	966	003	Aug. 25, 2018	Aug. 26, 2019

### For Harmonic & Flicker Test

For Harmonic / Flicker Test ( A --- site )					
Equipment	Manufacturer	Model#	Serial#	Last Cal.	Next Cal.
Harmonic / Flicker Analyzer	KIKUSUI	KHA1000	VA002445	Aug. 25, 2018	Aug. 26, 2019
AC Power Supply	KIKUSUI	PCR4000M	UK001879	Aug. 25, 2018	Aug. 26, 2019
Line Impedance network	KIKUSUI	LIN1020JF	UL001611	Aug. 25, 2018	Aug. 26, 2019

### For Electrostatic Discharge Immunity Test

For Electrostatic Discharge Immunity Test ( A --- site )					
Equipment	Manufacturer	Model#	Serial#	Last Cal.	Next Cal.
ESD Tester	KIKISUI	KES4201A	UH002321	Aug. 25, 2018	Aug. 26, 2019

### For RF Field Strength Susceptibility Test(SMQ)

For RF Field Strength Susceptibility Test (SMQ --- site )					
Equipment	Manufacturer	Model#	Serial#	Last Cal.	Next Cal.
Signal Generator	HP	8648A	3625U00573	Aug. 25, 2018	Aug. 26, 2019
Amplifier	A&R	500A100	17034	Aug. 25, 2018	Aug. 26, 2019
Amplifier	A&R	100W/1000M1	17028	Aug. 25, 2018	Aug. 26, 2019
Audio Analyzer (20Hz~1GHz)	Panasonic	2023B	202301/428	Aug. 25, 2018	Aug. 26, 2019
Isotropic Field Probe	A&R	FP2000	16755	Aug. 25, 2018	Aug. 26, 2019
Antenna	EMCO	3108	9507-2534	Aug. 25, 2018	Aug. 26, 2019
Log-periodic Antenna	A&R	AT1080	16812	Aug. 25, 2018	Aug. 26, 2019

### For Electrical Fast Transient /Burst Immunity Test

For Electrical Fast Transient/Burst Immunity Test ( A --- site )					
Equipment	Manufacturer	Model#	Serial#	Last Cal.	Next Cal.
Burst Tester	Prima	EFT61004AG	PR14054467	Aug. 25, 2018	Aug. 26, 2019
Coupling Clamp	Prima	EFT61004AG	BCTC009E	Aug. 25, 2018	Aug. 26, 2019

### For Surge Test

For Surge Test ( A --- site )					
Equipment	Manufacturer	Model#	Serial#	Last Cal.	Next Cal.
Burst Tester	Prima	EFT61004AG	PR14054467	Aug. 25, 2018	Aug. 26, 2019

### For Injected Currents Susceptibility Test

For Injected Currents Susceptibility Test ( A --- site )					
Equipment	Manufacturer	Model#	Serial#	Last Cal.	Next Cal.
C/S Test System	SCHLODER	CDG600	126B1281	Aug. 27, 2018	Aug. 26, 2019
CDN	SCHLODER	CDN-M2+3	A2210320/20 15	Aug. 27, 2018	Aug. 26, 2019
Injection Clamp	SCHLOBER	EMCL-20	132A1214/20 15	Aug. 27, 2018	Aug. 26, 2019

### For Voltage Dips Interruptions Test

For Voltage Dips Interruptions Test ( A --- site )					
Equipment	Manufacturer	Model#	Serial#	Last Cal.	Next Cal.
Dips Tester	Prima	DRP61011AG	PR14086284	Aug. 27, 2018	Aug. 26, 2019

### 3. CONDUCTED EMISSION AT THE MAINS TERMINALS TEST

#### 3.1. Block Diagram Of Test Setup

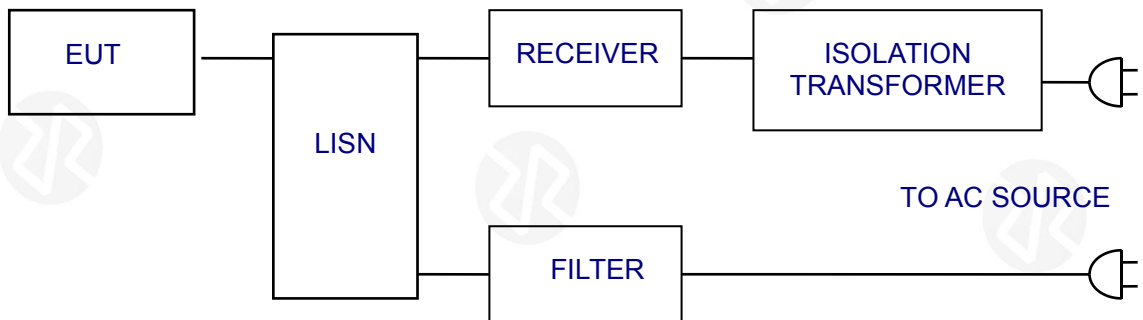

#### 3.2. Test Standard

EN 55014-1:2016

#### 3.3. Power Line Conducted Emission Limit

Frequency MHz	Limits dB( $\mu$ V)	
	Quasi-peak Level	Average Level
0.15 ~ 0.50	66 ~ 56*	56 ~ 46*
0.50 ~ 5.00	56	46
5.00 ~ 30.00	60	50

Notes: 1. \*Decreasing linearly with logarithm of frequency.

2. The lower limit shall apply at the transition frequencies.

#### 3.4. EUT Configuration on Test

The following equipments are installed on conducted emission test to meet EN 55014-1 requirement and operating in a manner which tends to maximize its emission characteristics in a normal application.

#### 3.5. Operating Condition of EUT

3.5.1 Setup the EUT and simulators as shown in Section 3.1.

3.5.2 Turn on the power of all equipments.

3.5.3 Let the EUT work in test modes and test it.

### 3.6. Test Procedure

The EUT is put on the ground and connected to the AC mains through a Artificial Mains Network (AMN). This provided a 50ohm coupling impedance for the tested equipments. Both sides of AC line are checked to find out the maximum conducted emission levels according to the **EN 55014-1** regulations during conducted emission test.

The bandwidth of the test receiver (R&S Test Receiver ESCI) is set at 10KHz.

The frequency range from 150 KHz to 30 MHz is investigated.

### 3.7. Test Result

PASS

Please refer to the following page.

Conducted Emission At The Mains Terminals Test Data			
Temperature:	24.5 °C	Relative Humidity:	54%
Pressure:	1009hPa	Phase :	Line
Test Voltage :	AC230V/50Hz	Test Mode:	ON Mode

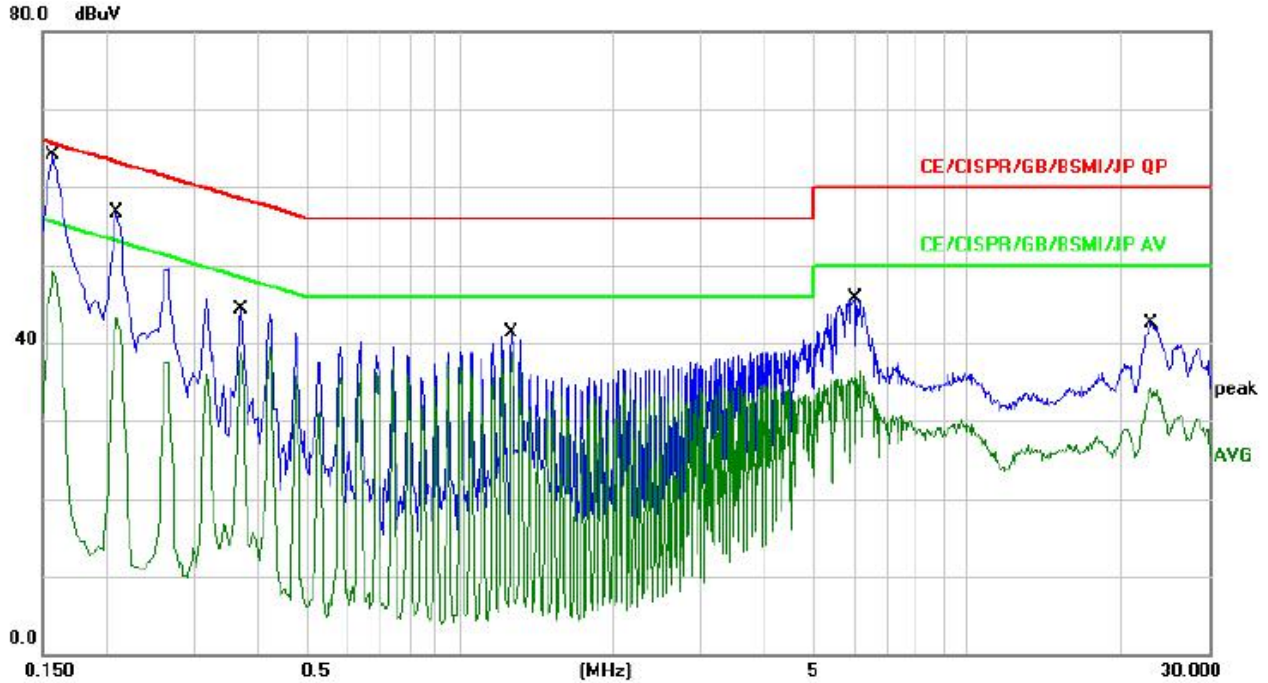

No.	Mk.	Freq. MHz	Reading Level dBuV	Correct Factor dB	Measure- ment dBuV	Limit dBuV	Over dB	Detector	Comment
1	*	0.1580	52.41	9.72	62.13	65.56	-3.43	QP	
2		0.1580	39.45	9.72	49.17	55.56	-6.39	AVG	
3		0.2100	46.99	9.63	56.62	63.20	-6.58	QP	
4		0.2100	33.69	9.63	43.32	53.20	-9.88	AVG	
5		0.3700	34.57	9.66	44.23	58.50	-14.27	QP	
6		0.3700	29.10	9.66	38.76	48.50	-9.74	AVG	
7		1.2660	31.67	9.71	41.38	56.00	-14.62	QP	
8		1.2660	29.25	9.71	38.96	46.00	-7.04	AVG	
9		6.0220	35.95	9.78	45.73	60.00	-14.27	QP	
10		6.0220	26.44	9.78	36.22	50.00	-13.78	AVG	
11		23.0700	32.46	10.01	42.47	60.00	-17.53	QP	
12		23.0700	24.09	10.01	34.10	50.00	-15.90	AVG	

Conducted Emission At The Mains Terminals Test Data			
Temperature:	24.5 °C	Relative Humidity:	54%
Pressure:	1009hPa	Phase :	Neutral
Test Voltage :	AC230V/50Hz	Test Mode:	ON Mode

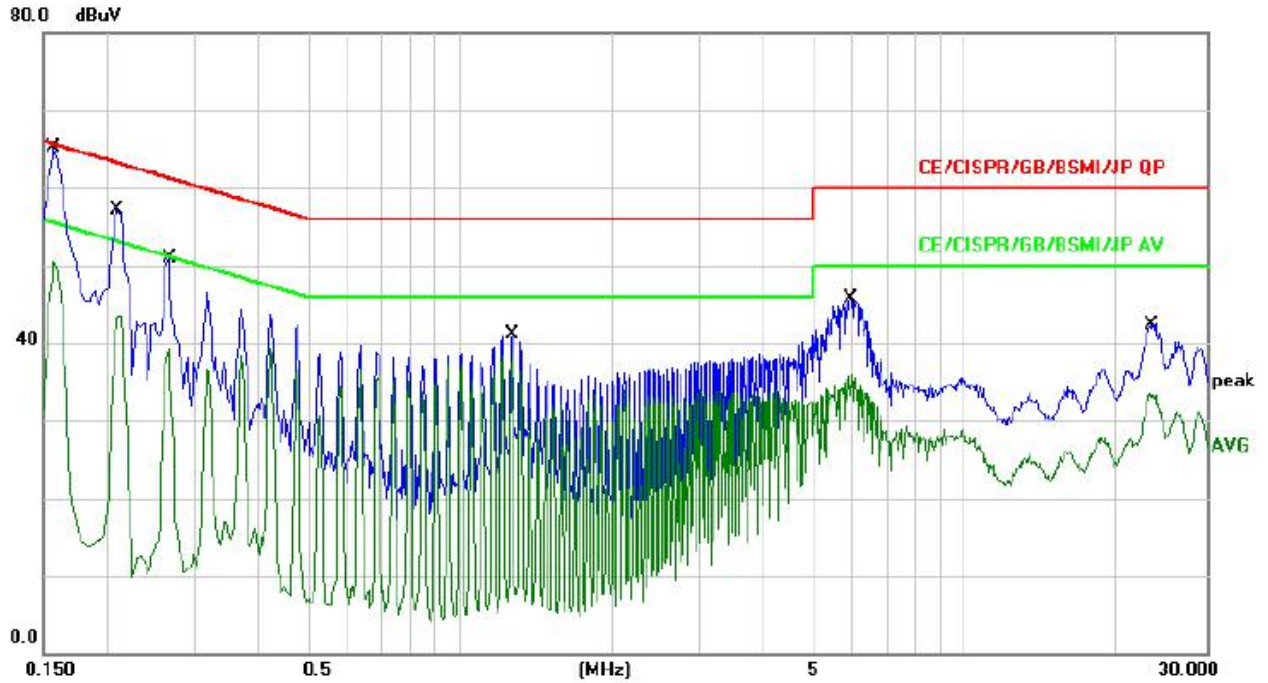

No.	Mk.	Freq. MHz	Reading Level dBuV	Correct Factor dB	Measure- ment dBuV	Limit dBuV	Over dB	Detector	Comment
1	*	0.1580	53.47	9.72	63.19	65.56	-2.37	QP	
2		0.1580	40.83	9.72	50.55	55.56	-5.01	AVG	
3		0.2100	47.40	9.63	57.03	63.20	-6.17	QP	
4		0.2100	33.91	9.63	43.54	53.20	-9.66	AVG	
5		0.2660	41.32	9.64	50.96	61.24	-10.28	QP	
6		0.2660	29.63	9.64	39.27	51.24	-11.97	AVG	
7		1.2700	31.40	9.71	41.11	56.00	-14.89	QP	
8		1.2700	28.77	9.71	38.48	46.00	-7.52	AVG	
9		5.9340	36.03	9.76	45.79	60.00	-14.21	QP	
10		5.9340	26.21	9.76	35.97	50.00	-14.03	AVG	
11		23.2580	32.42	10.01	42.43	60.00	-17.57	QP	
12		23.2580	23.43	10.01	33.44	50.00	-16.56	AVG	

## 4. RADIATION EMISSION TEST

### 4.1. Block Diagram of Test Setup

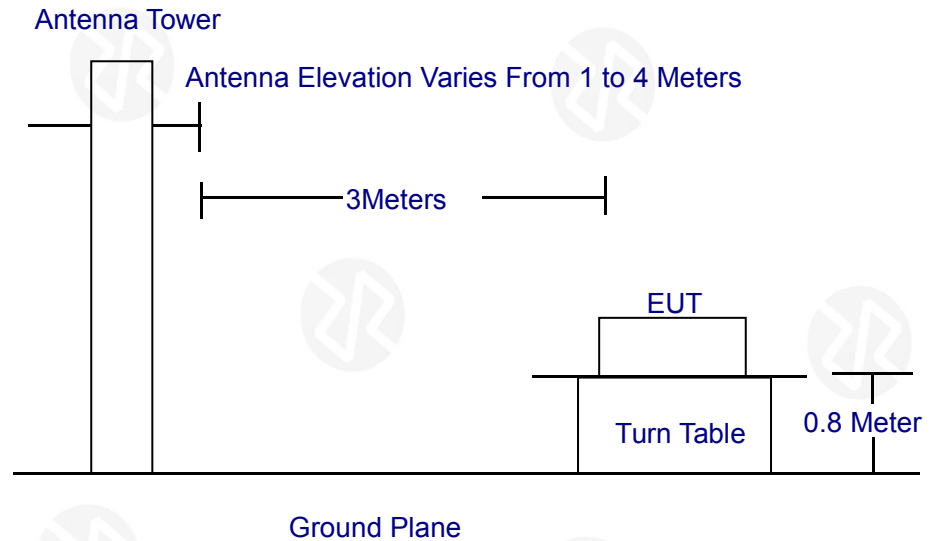

### 4.2. Test Standard

EN 55014-1:2016

### 4.3. Radiation Limit

Frequency MHz	Distance (Meters)	Field Strengths Limits dB( $\mu$ V)/m
		40.0
230 ~ 1000	3	47.0

Remark:

- (1) Emission level (dB( $\mu$ V)/m) = 20 log Emission level ( $\mu$ V/m)
- (2) The smaller limit shall apply at the cross point between two frequency bands.
- (3) Distance refers to the distance in meters between the measuring instrument, antenna and the closed point of any part of the device or system.

#### 4.4.EUT Configuration on Test

The EN 55014-1 regulations test method must be used to find the maximum emission during radiated emission test.

The configuration of EUT is the same as used in conducted emission test. Please refer to Section 2.2.

#### 4.5.Operating Condition of EUT

Same as conducted emission test, which is listed in Section 2.2 except the test set up replaced as Section 4.1.

#### 4.6.Test Procedure

The EUT and its simulators are placed on a turned table that is 0.8 meter above the ground. The turned table can rotate 360 degrees to determine the position of the maximum emission level. The EUT is set 3 meters away from the receiving antenna that is mounted on the antenna tower. The antenna can move up and down between 1 meter and 4 meters to find out the maximum emission level. Broadband antenna (calibrated biconical and log periodical antenna) is used as receiving antenna. Both horizontal and vertical polarization of the antenna is set on test. In order to find the maximum emission levels, the interface cable must be manipulated according to EN 55014-1 on radiated emission test.

The bandwidth setting on the field strength meter (R&S Test Receiver ESCI) is set at 120KHz.

The frequency range from 30MHz to 1000MHz is checked.

#### 4.7.Test Result

**PASS**

Please refer to the following page.

Radiation Emission Test Data			
Temperature:	24.5 °C	Relative Humidity:	54%
Pressure:	1009hPa	Phase :	Horizontal
Test Voltage :	AC230V/50Hz	Test Mode:	ON Mode



No. Mk.	Freq. MHz	Reading Level dBuV	Correct Factor dB	Measure- ment dBuV/m	Limit dB/m	Over dB	Antenna Height cm	Table Degree degree	Detector	Comment
1	45.8553	32.00	-14.02	17.98	40.00	-22.02			QP	
2 *	73.3593	41.18	-18.27	22.91	40.00	-17.09			QP	
3	150.5378	40.58	-18.97	21.61	40.00	-18.39			QP	
4	180.0165	40.90	-18.08	22.82	40.00	-17.18			QP	
5	234.9909	39.14	-15.72	23.42	47.00	-23.58			QP	
6	463.9696	30.09	-10.57	19.52	47.00	-27.48			QP	

Radiation Emission Test Data			
Temperature:	24.5 °C	Relative Humidity:	54%
Pressure:	1009hPa	Phase :	Vertical
Test Voltage :	AC230V/50Hz	Test Mode:	ON Mode



No. Mk.	Freq. MHz	Reading Level dBuV	Correct Factor dB	Measurement dBuV/m	Limit dB/m	Over dB	Antenna Height cm	Table Degree	Comment
1 *	44.1202	41.33	-14.16	27.17	40.00	-12.83	QP		
2	54.8348	41.62	-14.74	26.88	40.00	-13.12	QP		
3	144.3348	46.19	-19.24	26.95	40.00	-13.05	QP		
4	213.0151	43.07	-16.21	26.86	40.00	-13.14	QP		
5	454.3100	33.55	-10.59	22.96	47.00	-24.04	QP		
6	893.8567	26.48	-2.55	23.93	47.00	-23.07	QP		

## 5. HARMONIC CURRENT EMISSION TEST

### 5.1. Block Diagram of Test Setup

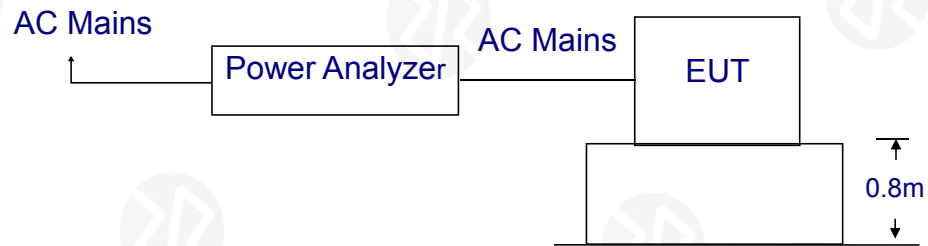

### 5.2. Test Standard

EN 61000-3-2:2014

### 5.3. Operating Condition of EUT

- 5.3.1 Setup the EUT as shown in Section 5.1.
- 5.3.2 Turn on the power of all equipments.
- 5.3.3 Let the EUT work in test mode and test it.

### 5.4. Test Procedure

The power cord of the EUT is connected to the output of the test system. Turn on the power of the EUT and use the test system to test the harmonic current level.

### 5.5. Test Results

**PASS**

Please refer to the following page.

File Settings Help

HA-PC Link Version 3.01  
HA1600 Firmware Issue 3.02

Equipment under Test

Serial Number Tested by

Measurement EN61000-3-2 (Harmonics) Date and Time of Test 27五月2017 16:07

Nominal Voltage 230 Volts Nominal Frequency 50 Hz 60 Hz

**Harmonics Settings**

Class A Professional No Limits Below 75 watts

Test Method Standard EN61000-4-7:1993

Current Range 12 A Peak Range Up Range Down Lock Range

Test Status Free Run Overload. Hold Abort Test Timed Test Duration 150 Secs Reset Meter Start Timed Test

N	Filtered	Limit	Avg.	%Limit	Max.	%Limit	N	Filtered	Limit	Avg.	%Limit	Max.	%Limit
1	1193.2						2	52.8	1080.0	6.0	0.6	52.8	4.9
3	166.5	2300.0	236.4	10.3	1004.1	43.7	4	32.7	430.0	4.0	0.9	32.7	7.6
5	103.9	1140.0	45.7	4.0	185.2	16.2	6	13.3	300.0	3.5	1.2	16.1	5.4
7	44.5	770.0	10.8	1.4	44.5	5.8	8	6.1	230.0	3.4	1.5	14.3	6.2
9	13.6	400.0	8.9	2.2	27.6	6.9	10	5.7	184.0	3.0	1.6	12.9	7.0
11	13.6	330.0	5.4	1.6	16.5	5.0	12	2.8	153.3	2.8	1.8	12.5	8.2
13	7.9	210.0	7.2	3.4	26.2	12.5	14	2.8	131.4	3.0	2.3	13.6	10.4
15	2.8	150.0	4.6	3.1	15.1	10.1	16	2.5	115.0	2.6	2.3	13.3	11.6
17	5.7	132.3	5.4	4.1	13.6	10.3	18	1.4	102.2	2.3	2.3	9.7	9.5
19	3.5	118.4	4.9	4.1	11.5	9.7	20	1.4	92.0	2.1	2.3	8.9	9.7
21	1.7	107.1	2.6	2.4	6.8	6.3	22	1.0	83.6	2.0	2.4	7.9	9.4
23	2.5	97.8	3.3	3.4	8.9	9.1	24	1.7	76.7	1.8	2.3	7.5	9.8
25	0.3	90.0	1.7	1.9	5.0	5.6	26	1.7	70.8	1.6	2.3	6.4	9.0
27	1.7	83.3	2.5	3.0	5.0	6.0	28	1.0	65.7	1.4	2.1	5.7	8.7
29	1.4	77.6	1.5	1.9	4.3	5.5	30	0.7	61.3	1.2	2.0	5.7	9.3
31	0.3	72.6	0.4	0.6	1.7	2.3	32	0.7	57.5	1.2	2.1	4.6	8.0
33	1.4	68.2	1.1	1.6	2.1	3.1	34	0.7	54.1	1.0	1.8	3.9	7.2
35	0.7	64.3	1.0	1.6	1.4	2.2	36	0.7	51.1	0.9	1.8	3.5	6.8
37	0.7	60.8	0.9	1.5	1.4	2.3	38	0.7	48.4	0.7	1.4	2.8	5.8
39	1.7	57.7	1.7	2.9	2.1	3.6	40	0.3	46.0	0.7	1.5	2.5	5.4
P	4.6	251.4	6.1	2.4	13.3	5.3							

Harmonics Display Options Waveform Histogram Table

**SUPPLY VOLTAGE** Frequency 49.98 Hz  
229.55 V<sub>rms</sub> Peak at 90.8 Deg.  
324.46 V<sub>pk</sub> Crest Factor 1.413

**LOAD POWER** 1072.5 W 1108.6 VA  
1072.50 W<sub>max</sub> Power Factor 0.967

**LOAD CURRENT** 0.602 A<sub>rms</sub> Total Harmonics 212.6 mA  
1.227 A<sub>pk</sub> Crest Factor 2.038

**HARMONICS SUMMARY**  
PASS  
Class A Limits Apply  
Actual Power 1072.5 W  
Supply Meets EN Requirements

File Settings Help

HA-PC Link Version 3.01  
HA1600 Firmware Issue 3.02

Equipment under Test

Serial Number Tested by

Measurement EN61000-3-2 (Harmonics) Date and Time of Test 27五月2017 16:07

Nominal Voltage 230 Volts Nominal Frequency 50 Hz 60 Hz

**Harmonics Settings**

Class A Professional No Limits Below 75 watts

Test Method Standard EN61000-4-7:1993

Current Range 12 A Peak Range Up Range Down Lock Range

Test Status Free Run Overload. Hold Abort Test Timed Test Duration 150 Secs Reset Meter Start Timed Test

**Harmonics Histogram** 1.0A/div

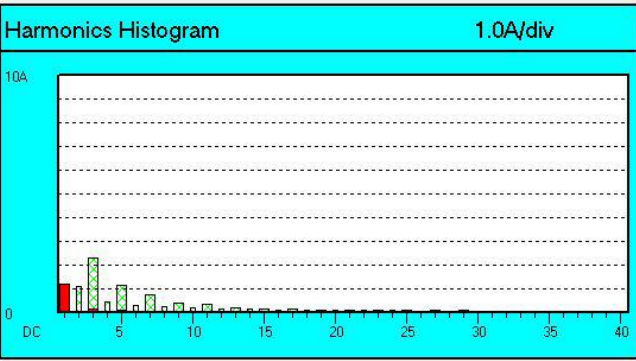

Scale Up Scale Down Auto-set Scale

Harmonics Display Options Waveform Histogram Table

**SUPPLY VOLTAGE** Frequency 49.98 Hz  
229.55 V<sub>rms</sub> Peak at 90.8 Deg.  
324.46 V<sub>pk</sub> Crest Factor 1.413

**LOAD POWER** 1072.5 W 1108.6 VA  
1072.50 W<sub>max</sub> Power Factor 0.967

**LOAD CURRENT** 0.602 A<sub>rms</sub> Total Harmonics 212.6 mA  
1.227 A<sub>pk</sub> Crest Factor 2.038

**HARMONICS SUMMARY**  
PASS  
Class A Limits Apply  
Actual Power 1072.5 W  
Supply Meets EN Requirements

File Settings Help

HA-PC Link Version 3.01  
HA1600 Firmware Issue 3.02

Equipment under Test

Serial Number \_\_\_\_\_ Tested by \_\_\_\_\_

Measurement EN61000-3-2 (Harmonics) Date and Time of Test 27 五月 2017 16:08

Nominal Voltage 230 Volts Nominal Frequency  50 Hz  60 Hz

**Harmonics Settings**

Class **A** Professional  No Limits Below 75 watts

Test Method Standard EN61000-4-7:1993

**Current Range** 12 A Peak Range Up Range Down Lock Range

**Test Status** Free Run

Overload. Hold Abort Test

Timed Test Duration 150 Secs Reset Meter Start Timed Test

**Waveform Graph** 3A/div

Join Dots

Harmonics Display Options  Waveform  Histogram  Table

<b>SUPPLY VOLTAGE</b>		Frequency	<b>49.98 Hz</b>	<b>HARMONICS SUMMARY</b>	
229.55 V <sub>rms</sub>	Peak at	90.8 Deg.	PASS		
324.46 V <sub>pk</sub>	Crest Factor	<b>1.413</b>	Class A Limits Apply.		
<b>LOAD POWER</b>		1108.6 VA	Actual Power 1072.5 W		
1072.5 W	Power Factor	<b>0.967</b>	Supply Meets EN Requirements		
<b>LOAD CURRENT</b>		Total Harmonics	<b>212.6 mA</b>		
0.602 A <sub>rms</sub>	Crest Factor	<b>2.038</b>			
1.227 A <sub>pk</sub>					

## 6. VOLTAGE FLUCTUATIONS & FLICKER TEST

### 6.1. Block Diagram of Test Setup

Same as Section 6.1.

### 6.2. Test Standard

EN 61000-3-3:2013

### 6.3. Operating Condition of EUT

Same as Section 5.3.. The power cord of the EUT is connected to the output of the test system. Turn on the power of the EUT and use the test system to test the harmonic current level.

#### Flicker Test Limit

Test items	Limits
Pst	1.0
dc	3.3%
Tmax	4.0%
dt	Not exceed 3.3% for 500ms

### 6.4. Test Procedure

The power cord of the EUT is connected to the output of the test system. Turn on the power of the EUT and use the test system to test the harmonic current level.

### 6.5. Test Results

**PASS**

Please refer to the following page.

Flicker Test Data			
Temperature:	24.5 °C	Relative Humidity:	54%
Pressure:	1009hPa	Phase :	Vertical
Test Voltage :	AC230V/50Hz	Test Mode:	ON

Voltage Fluctuation	Limit	Value
Relative Voltage Change Characteristic Tmax (dc>3%)	500 ms	0 ms
Maximum Relative Voltage Change dmax	4%	0.00
	6%	/
	7%	/
Relative Steady-state Voltage Change dc	3.3%	0.00

Flicker	Limit	Value
Short-term Flicker Indicator Pst	1.0	0.064
Long-term Flicker Indicator Plt	0.65	/

## 7. ELECTROSTATIC DISCHARGE IMMUNITY TEST

### 7.1. Block Diagram of Test Setup

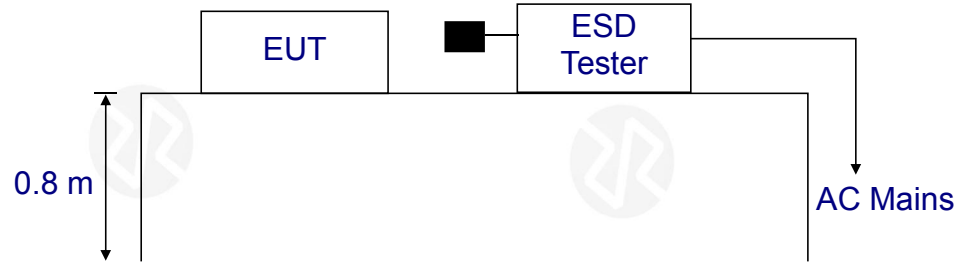

### 7.2. Test Standard

EN 55014-2:2015, EN 61000-4-2:2009

Severity Level: 3 / Air Discharge:  $\pm 8\text{KV}$

Level: 2 / Contact Discharge:  $\pm 4\text{KV}$

### 7.3. Severity Levels and Performance Criterion

#### 7.3.1 Severity level

Level	Test Voltage Contact Discharge (KV)	Test Voltage Air Discharge (KV)
1.	$\pm 2$	$\pm 2$
2.	$\pm 4$	$\pm 4$
3.	$\pm 6$	$\pm 8$
4.	$\pm 8$	$\pm 15$
X	Special	Special

#### 7.3.2 Performance criterion : B

- A.** The apparatus shall continue to operate as intended during the test. No degradation of performance or loss of function is allowed below a performance level (or permissible loss of performance) specified by the manufacturer, when the apparatus is used as i

- B.** The apparatus shall continue to operate as intended after the test. No degradation of performance or loss of function is allowed below a performance level (or permissible loss of performance) specified by the manufacturer, when the apparatus is used as intended. During the test, degradation of performance is allowed, however, no change of actual operating state or stored data is allowed. If the minimum performance level or the permissible performance loss is not specified by the manufacturer, then either of these may be derived from the product description and documentation, and from what the user may reasonably expect from the apparatus if used as intended.
- C.** Temporary loss of function is allowed, provided the function is self-recoverable or can be restored by the operation of the controls, or by any operation specified in the instructions for use.

#### 7.4.EUT Configuration

The following equipments are installed on Electrostatic Discharge Immunity test to meet EN 55014-2:2015, EN 61000-4-2:2009, requirement and operating in a manner which tends to maximize its emission characteristics in a normal application. The configuration of EUT is the same as used in conducted emission test.

Please refer to Section 2.4.

#### 7.5.Operating Condition of EUT

Same as conducted emission measurement, which is listed in Section 3.5 except the test setup replaced by Section 7.1.2.

#### 7.6.Test Procedure

##### 7.6.1 Air Discharge:

This test is done on a non-conductive surface. The round discharge tip of the discharge electrode shall be approached as fast as possible to touch the EUT. After each discharge, the discharge electrode shall be removed from the EUT. The generator is then re-triggered for a new single discharge and repeated 10 times for each pre-selected test point. This procedure shall be repeated until all the air discharge completed.

##### 7.6.2 Contact Discharge:

All the procedure shall be same as Section 7.6.1. Except that the tip of the discharge electrode shall touch the EUT before the discharge switch is operated.

##### 7.6.3 Indirect discharge for horizontal coupling plane

At least 10 single discharges (in the most sensitive polarity) shall be applied at the front edge of each HCP opposite the center point of each unit (if applicable) of the EUT and 0.1m from the front of the EUT. The long axis of the discharge electrode shall be in the plane of the HCP and perpendicular to its front edge during the discharge.

#### 7.6.4 Indirect discharge for vertical coupling plane

At least 10 single discharges (in the most sensitive polarity) shall be applied to the center of one vertical edge of the coupling plane. The coupling plane, of dimensions 0.5m X 0.5m, is placed parallel to, and positioned at a distance of 0.1m from the EUT. Discharges shall be applied to the coupling plane, with this plane in sufficient different positions that the four faces of the EUT are complete illuminated.

#### 7.7. Test Results

**PASS**

Please refer to the following page.

ESD Test Data				
Temperature:	24.5°C	Humidity:	53%	
Power Supply :	AC230V/50Hz	Test Mode:	On	
Air Discharge: ± 8KV				
Contact Discharge: ± 4KV				
Test Points	Air Discharge	Contact Discharge	Performance Criterion	Result
Enclosure	±2,4,8KV	N/A	B	PASS
Slit	±2,4,8KV	N/A	B	PASS
Metal Part	N/A	±2,4 KV	B	PASS
VCP	N/A	±2,4 KV	B	PASS
HCP	N/A	±2,4 KV	B	PASS
Note: N/A				

## 8. RF FIELD STRENGTH SUSCEPTIBILITY TEST

### 8.1. Block Diagram of Test Setup

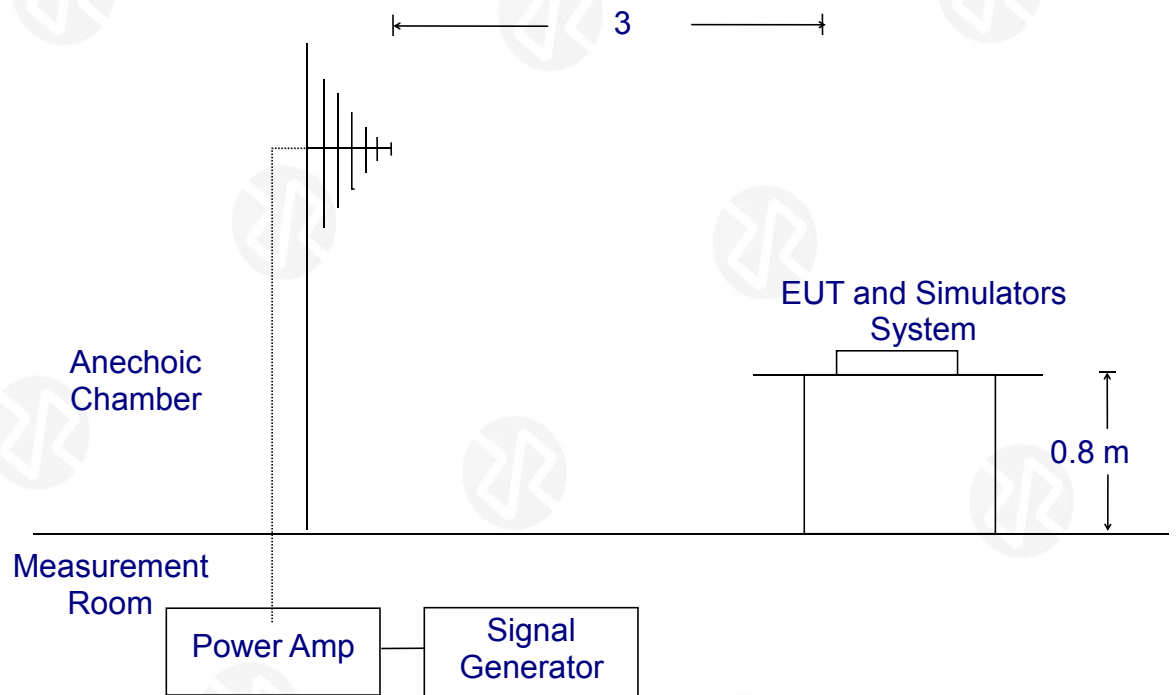

### 8.2. Test Standard

EN 55014-2:2015,  
 EN 61000-4-3: 2006+A1:2008+A2:2010

Severity Level 2, 3V / m

### 8.3. Severity Levels and Performance Criterion

#### 8.3.1. Severity level

Level	Field Strength V/m
1.	1
2.	3
3.	10
X.	Special

### 8.3.2. Performance criterion: A

- A、 The apparatus shall continue to operate as intended during the test. No degradation of performance or loss of function is allowed below a performance level (or permissible loss of performance) specified by the manufacturer, when the apparatus is used as i
- B、 The apparatus shall continue to operate as intended after the test. No degradation of performance or loss of function is allowed below a performance level (or permissible loss of performance) specified by the manufacturer, when the apparatus is used as intended. During the test, degradation of performance is allowed, however, no change of actual operating state or stored data is allowed. If the minimum performance level or the permissible performance loss is not specified by the manufacturer, then either of these may be derived from the product description and documentation, and from what the user may reasonably expect from the apparatus if used as intended.
- C、 Temporary loss of function is allowed, provided the function is self-recoverable or can be restored by the operation of the controls, or by any operation specified in the instructions for use.

### 8.4.EUT Configuration on Test

The following equipments are installed on Electrical Fast Transient/Burst Immunity test to meet EN 55014-2:2015, EN 61000-4-4:2012, requirement and operating in a manner which tends to maximize its emission characteristics in a normal application. The configuration of EUT is the same as used in conducted emission test.

Please refer to Section 3.4.

### 8.5.Operating Condition of EUT

Same as conducted emission measurement, which is listed in Section 2.5 except the test setup replaced by Section 8.1.

## 8.6. Test Procedure

The EUT and its simulators are placed on a turn table which is 0.8 meter above ground. EUT is set 3 meter away from the transmitting antenna which is mounted on an antenna tower. Both horizontal and vertical polarization of the antenna are set on test. Each of the four sides of EUT must be faced this transmitting antenna and measured individually.

All the scanning conditions are as follows :

Condition of Test	Remarks
1. Fielded Strength	3 V/m (Severity Level 2)
2. Radiated Signal	Modulated
3. Scanning Frequency	80 – 1000 MHz
4. Dwell time of radiated	0.0015 decade/s
5. Waiting Time	1 Sec.

## 8.7. Test Results

**PASS**

Please refer to the following page.

R/S Test Data			
Temperature : 25°C		Humidity : 53%	
Field Strength: 3 V/m		Criterion: A	
Power Supply: AC230V/50Hz		Frequency Range: 80 MHz to 1000 MHz	
Modulation: <input checked="" type="checkbox"/> AM <input type="checkbox"/> Pulse <input type="checkbox"/> none 1 KHz 80%			
Test Mode : On			
Frequency Range : 80-1000MHz			
Steps		1 %	
	Horizontal	Vertical	Result
Front	A	A	Pass
Right	A	A	Pass
Rear	A	A	Pass
Left	A	A	Pass
Note: N/A			

## 9. ELECTRICAL FAST TRANSIENT/BURST IMMUNITY TEST

### 9.1. Block Diagram of EUT Test Setup



### 9.2. Test Standard

EN 55014-2:2015, EN 61000-4-4:2012

### 9.3. Severity Levels and Performance Criterion

Severity Level 2 at 1KV, Pulse Rise time & Duration: 5 nS / 50 nS

Severity Level:

Open Circuit Output Test Voltage $\pm 10\%$		
Level	On power ports	On I/O(Input/Output) Signal data and control ports
1.	0.5KV	0.25KV
2.	1KV	0.5KV
3.	2KV	1KV
4.	4KV	2KV
X.	Special	Special

#### Performance criterion: B

- A. The apparatus shall continue to operate as intended during the test. No degradation of performance or loss of function is allowed below a performance level (or permissible loss of performance) specified by the manufacturer, when the apparatus is used as i
- B. The apparatus shall continue to operate as intended after the test. No degradation of performance or loss of function is allowed below a performance level (or permissible loss of performance) specified by the manufacturer, when the apparatus is used as intended. During the test, degradation of performance is allowed, however, no change of actual operating state or stored data is allowed. If the minimum performance level or the permissible performance loss is not specified by the manufacturer, then either of these may be derived from the product description and documentation, and from what the user may reasonably expect from the apparatus if used as intended.
- C. Temporary loss of function is allowed, provided the function is self-recoverable or can be restored by the operation of the controls, or by any operation specified in the instructions for use.

#### 9.4.EUT Configuration on Test

The following equipments are installed on Electrical Fast Transient/Burst Immunity test to meet EN 55014-2:2015, EN 61000-4-4:2012, requirement and operating in a manner which tends to maximize its emission characteristics in a normal application. The configuration of EUT is the same as used in conducted emission test.

Please refer to Section 3.4.

#### 9.5.Operating Condition of EUT

Same as conducted emission measurement, which is listed in Section 2.6 except the test setup replaced by Section 9.1.

#### 9.6.Test Procedure

EUT shall be placed 0.8m high above the ground reference plane which is a min.1m\*1m metallic sheet with 0.65mm minimum thickness. This reference ground plane shall project beyond the EUT by at least 0.1m on all sides and the minimum distance between EUT and all other conductive structure, except the ground plane beneath the EUT, shall be more than 0.5m

9.6.1. For input and output AC power ports:

The EUT is connected to the power mains by using a coupling device which couples the EFT interference signal to AC power lines. Both polarities of the test voltage should be applied during compliance test and the duration of the test is 2 minutes.

### 9.7. Test Results

**PASS**

Please refer to the following page.

EFT Test Data				
Temperature:	24.5℃	Humidity:	53%	
Power Supply :	AC230V/50Hz	Test Mode:	On	
Coupling Line	Test Voltage		Performance Criterion	Result
	±0.5kV	±1kV		
L	±0.5kV	±1kV	B	PASS
N	±0.5kV	±1kV	B	PASS
L-N	±0.5kV	±1kV	B	PASS
PE	±0.5kV	±1kV	B	N/A
L-PE	±0.5kV	±1kV	B	N/A
N-PE	±0.5kV	±1kV	B	N/A
L-N-PE	±0.5kV	±1kV	B	N/A
DC Line	/	/		/
Note: N/A				

## 10. SURGE TEST

### 10.1. Block Diagram of EUT Test Setup

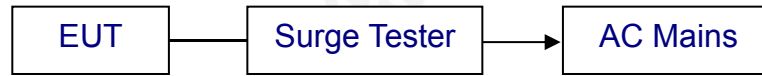

### 10.2. Test Standard

EN 55014-2:2015, EN61000-4-5:2014

### 10.3. Severity Levels and Performance Criterion

Severity Level: Line to Line, Level 2 at 1KV;

Severity Level: Line to Earth, Level 3 at 2KV.

Severity Level	Open-Circuit Test Voltage (KV)
1.	0.5
2.	1.0
3.	2.0
4.	4.0
X.	Special

#### Performance criterion: B

- A. The apparatus shall continue to operate as intended during the test. No degradation of performance or loss of function is allowed below a performance level (or permissible loss of performance) specified by the manufacturer, when the apparatus is used as i
- B. The apparatus shall continue to operate as intended after the test. No degradation of performance or loss of function is allowed below a performance level (or permissible loss of performance) specified by the manufacturer, when the apparatus is used as intended. During the test, degradation of performance is allowed, however, no change of actual operating state or stored data is allowed. If the minimum performance level or the permissible performance loss is not specified by the manufacturer, then either of these may be derived from the product description and documentation, and from what the user may reasonably expect from the apparatus if used as intended.
- C. Temporary loss of function is allowed, provided the function is self-recoverable or can be restored by the operation of the controls, or by any operation specified in the instructions for use.

#### 10.4. EUT Configuration on Test

The following equipments are installed on Electrical Fast Transient/Burst Immunity test to meet EN 55014-2:2015, EN61000-4-5:2014, requirement and operating in a manner which tends to maximize its emission characteristics in a normal application

The configuration of EUT is the same as used in conducted emission test. Please refer to Section 3.4.

#### 10.5. Operating Condition of EUT

Same as conducted emission measurement, which is listed in Section 2.7 except the test setup replaced by Section 10.1.

#### 10.6. Test Procedure

- 1) Set up the EUT and test generator as shown on section 10.1
- 2) For line to line coupling mode, provide a 1KV 1.2/50us voltage surge (at open-circuit condition) and 8/20us current surge to EUT selected points.
- 3) At least 5 positive and 5 negative (polarity) tests with a maximum 1/min repetition rate are conducted during test.
- 4) Different phase angles are done individually.
- 5) Repeat procedure 2) to 4) except the open-circuit test voltage change from 1KV to 2KV for line to earth coupling mode test.
- 6) Record the EUT operating situation during compliance test and decide the EUT immunity criterion for above each test.

### 10.7. Test Result

**PASS**

Please refer to the following page.

Surge Test Data						
Temperature:		24.5℃		Humidity:		53%
Power Supply :		AC230V/50Hz		Test Mode:		On
Location	Polarity	Phase Angle	No of Pulse	Pulse Voltage (KV)	Performance Criterion	Result
L-N	+	90	5	1	B	Pass
	-	90	5	1		Pass
	+	270	5	1		Pass
	-	270	5	1		Pass
L-PE	+	90	5	2		N/A
	-	90	5	2		N/A
	+	270	5	2		N/A
	-	270	5	2		N/A
N-PE	+	90	5	2		N/A
	-	90	5	2		N/A
	+	270	5	2		N/A
	-	270	5	2		N/A

Note: N/A

## 11. INJECTED CURRENTS SUSCEPTIBILITY TEST

### 11.1. Block Diagram of EUT Test Setup

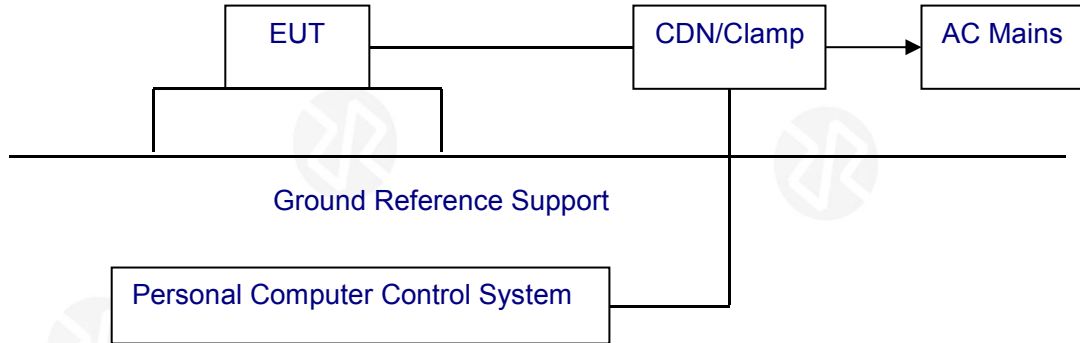

### 11.2. Test Standard

EN 55014-2:2015, EN61000-4-6:2014

### 11.3. Severity Levels and Performance Criterion

Severity Level 2: 3V( rms ), 150KHz ~ 80MHz

Severity Level:

Level	Field Strength V
1.	1
2.	3
3.	10
X.	Special

**Performance criterion: A**

- A. The apparatus shall continue to operate as intended during the test. No degradation of performance or loss of function is allowed below a performance level (or permissible loss of performance) specified by the manufacturer, when the apparatus is used as intended.
- B. The apparatus shall continue to operate as intended after the test. No degradation of performance or loss of function is allowed below a performance level (or permissible loss of performance) specified by the manufacturer, when the apparatus is used as intended. During the test, degradation of performance is allowed, however, no change of actual operating state or stored data is allowed. If the minimum performance level or the permissible performance loss is not specified by the manufacturer, then either of these may be derived from the product description and documentation, and from what the user may reasonably expect from the apparatus if used as intended.
- C. Temporary loss of function is allowed, provided the function is self-recoverable or can be restored by the operation of the controls, or by any operation specified in the instructions for use.

**11.4. EUT Configuration on Test**

The configuration of EUT is the same as used in conducted emission test. Please refer to Section 2.8.

**11.5. Operating Condition of EUT**

Same as conducted emission test, which is listed in Section 2.8 except the test set up replaced as Section 11.1.

**11.6. Test Procedure**

- 1) Set up the EUT, CDN and test generator as shown on section 11.1
- 2) Let EUT work in test mode and measure.
- 3) The EUT and supporting equipments are placed on an insulating support 0.1m high above a ground reference plane. CDN (coupling and decoupling device) is placed on the ground plane at above 0.1-0.3m from EUT. Cables between CDN and EUT are as short as possible, and their height above the ground reference plane shall be between 30 and 50 mm (where possible).
- 4) The disturbance signal described below is injected to EUT through CDN.
- 5) The EUT operates within its operational mode(s) under intended climatic conditions after power on.

- 6) The frequency range is swept from 150KHz to 80MHz using 3V signal level, and with the disturbance signal 80% amplitude modulated with a 1KHz sine wave
- 7) The rate of sweep shall not exceed  $1.5 \times 10^{-3}$  decades/s. Where the frequency is swept incrementally, the step size shall not exceed 1% of the start and thereafter 1% of the preceding frequency value.
- 8) Recording the EUT operating situation during compliance test and decide the EUT immunity criterion for above each test.

### 11.7. Test Result

**PASS**

Please refer to the following page.

CS Test Data						
Temperature:		24.5°C		Humidity:		53%
Power Supply :		AC230V/50Hz		Test Mode:		On
Frequency Range(MHz)	Injected Position	Strength	Modulation Signal	Freq. Step	Performance Criterion	Result
150KHz ~ 80MHz	AC Line	3V(rms), Unmodulated	AM 80%, 1kHz sine wave	1%	A	Pass
150KHz ~ 80MHz	DC Line	3V(rms), Unmodulated	AM 80%, 1kHz sine wave	1%	/	/
Note: N/A						

## 12. VOLTAGE DIPS AND INTERRUPTIONS TEST

### 12.1. Block Diagram of EUT Test Setup



### 12.2. Test Standard

EN 55014-2:2015, EN61000-4-11:2004

### 12.3. Severity Levels and Performance Criterion

Severity Level:

Input and Output AC Power Ports.

- Voltage Dips.
- Voltage Interruptions.

Environmental Phenomena	Test Specification	Units	Performance Criterion
Voltage Dips	70 25	% Reduction period	C
	40 10	% Reduction period	C
Voltage Interruptions	0 0.5	% Reduction period	C

**Performance criterion:** B, C, C

- A. The apparatus shall continue to operate as intended during the test. No degradation of performance or loss of function is allowed below a performance level (or permissible loss of performance) specified by the manufacturer, when the apparatus is used as i
- B. The apparatus shall continue to operate as intended after the test. No degradation of performance or loss of function is allowed below a performance level (or permissible loss of performance) specified by the manufacturer, when the apparatus is used as intended. During the test, degradation of performance is allowed, however, no change of actual operating state or stored data is allowed. If the minimum performance level or the permissible performance loss is not specified by the manufacturer, then either of these may be derived from the product description and documentation, and from what the user may reasonably expect from the apparatus if used as intended.
- C. Temporary loss of function is allowed, provided the function is self-recoverable or can be restored by the operation of the controls, or by any operation specified in the instructions for use.

#### 12.4. EUT Configuration on Test

The configuration of EUT is the same as used in conducted emission test. Please refer to Section 2.10.

#### 12.5. Operating Condition of EUT

Same as conducted emission test, which is listed in Section 2.10 except the test set up replaced as Section 13.1.

#### 12.6. Test Procedure

- 1) Set up the EUT and test generator as shown on section 13.1
- 2) The interruption is introduced at selected phase angles with specified duration. There is a 3mins minimum interval between each test event.
- 3) After each test a full functional check is performed before the next test.
- 4) Repeat procedures 2 & 3 for voltage dips, only the level and duration is changed.
- 5) Record any degradation of performance.

#### 12.7. Test Result

**PASS**

Please refer to the following page.

DIPS Test Data			
Temperature:	24.5℃	Humidity:	53%
Power Supply :	AC230V/50Hz	Test Mode:	On
Environmental Phenomena	Test Specification	Units	Performance Criterion
Voltage Dips	70 25	% Reduction period	C
	40 10	% Reduction period	C
Voltage Interruptions	0 0.5	% Reduction period	C

### 13. EUT PHOTOGRAPHS

EUT Photo 1



EUT Photo 2

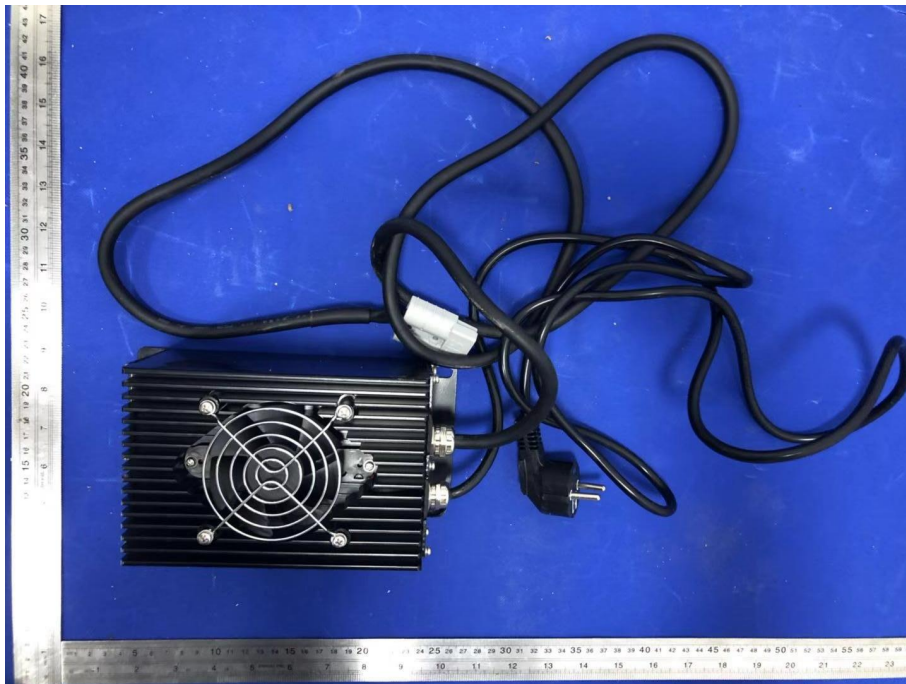

EUT Photo 3

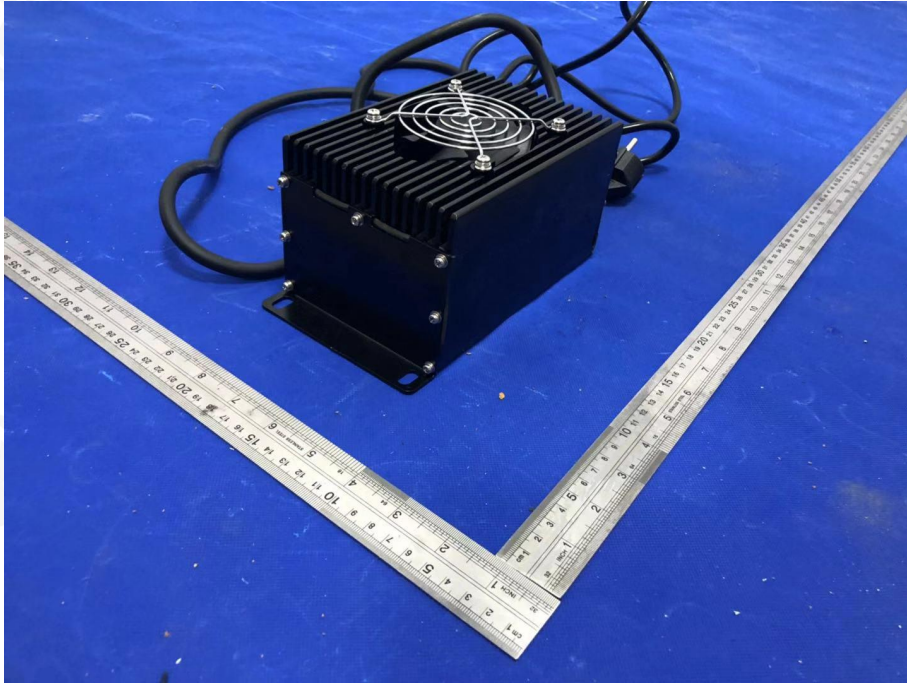

EUT Photo 4



EUT Photo 5

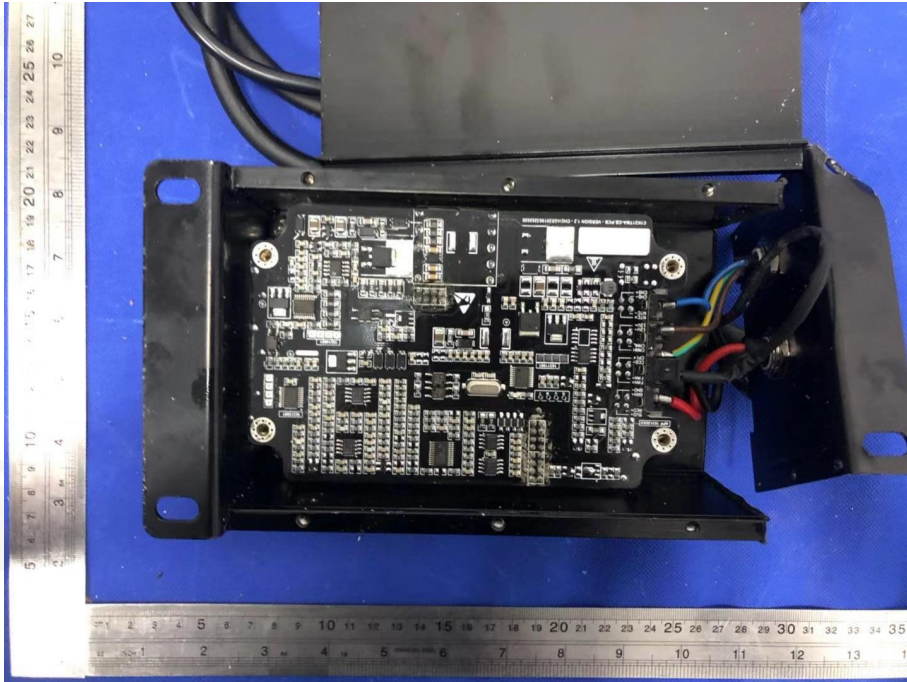

## 14. EUT TEST PHOTOGRAPHS

CE

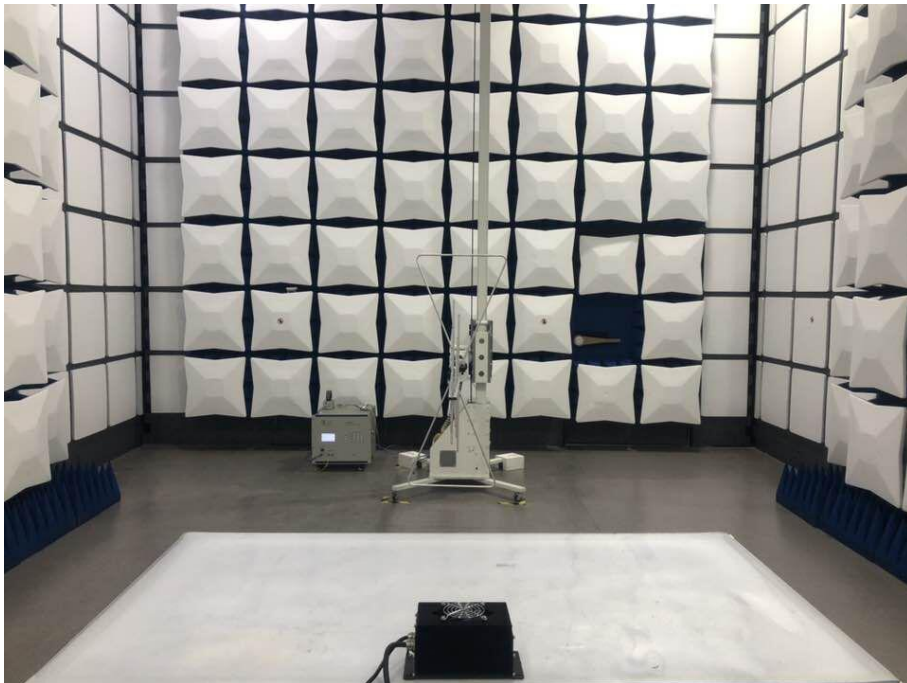

\*\*\*\*\* END OF REPORT \*\*\*\*\*